

150# ANSI FLANGE RATING

| LINE SIZE | A | B | C | T | L | W | WEIGHT | | |
|-----------|--------|--------|--------|-------|-------|-------|--------|----|-----|
| | | | | | | | 1 | 2 | 3 |
| 1/2" | 1.750 | .625 | 2.375 | .125 | 4.000 | 1.500 | 1 | 1 | 1 |
| 3/4" | 2.125 | .820 | 2.750 | .125 | 4.000 | 1.500 | 1 | 1 | 1 |
| 1" | 2.500 | 1.050 | 3.125 | .125 | 4.000 | 1.500 | 1 | 1 | 1 |
| 1 1/4" | 2.875 | 1.660 | 3.500 | .250 | 4.000 | 1.500 | 1 | 1 | 1 |
| 1 1/2" | 3.250 | 1.900 | 3.875 | .250 | 4.000 | 1.500 | 1 | 1 | 1 |
| 2" | 4.000 | 2.380 | 4.750 | .250 | 4.000 | 2.000 | 2 | 1 | 2 |
| 2 1/2" | 4.750 | 2.800 | 5.000 | .250 | 4.000 | 2.000 | 2 | 2 | 3 |
| 3" | 5.250 | 3.500 | 6.000 | .250 | 4.000 | 2.500 | 2 | 2 | 3 |
| 3 1/2" | 6.250 | 4.000 | 7.000 | .375 | 4.000 | 2.500 | 2 | 2 | 3 |
| 4" | 6.750 | 4.500 | 7.500 | .375 | 4.000 | 2.500 | 3 | 2 | 5 |
| 5" | 7.625 | 5.562 | 8.500 | .375 | 4.000 | 3.000 | 3 | 2 | 5 |
| 6" | 8.625 | 6.625 | 9.500 | .500 | 4.000 | 3.000 | 7 | 4 | 10 |
| 8" | 10.875 | 8.625 | 11.750 | .500 | 4.000 | 3.000 | 14 | 7 | 20 |
| 10" | 13.250 | 10.750 | 14.250 | .625 | 5.000 | 4.000 | 26 | 12 | 35 |
| 12" | 16.000 | 12.750 | 17.000 | .750 | 5.000 | 4.000 | 45 | 21 | 62 |
| 14" | 17.625 | 14.000 | 18.750 | .750 | 5.000 | 4.250 | 53 | 24 | 74 |
| 16" | 20.125 | 16.000 | 21.250 | .875 | 5.000 | 4.250 | 92 | 40 | 127 |
| 18" | 21.500 | 18.000 | 22.750 | 1.000 | 5.000 | 4.500 | 105 | 39 | 139 |
| 20" | 23.750 | 20.000 | 25.000 | 1.125 | 5.000 | 4.750 | 145 | 50 | 188 |
| 24" | 28.125 | 24.000 | 29.500 | 1.250 | 5.000 | 5.500 | 245 | 80 | 315 |

300# ANSI FLANGE RATING

| LINE SIZE | A | B | C | T | L | W | WEIGHT | | |
|-----------|--------|--------|--------|-------|-------|-------|--------|-----|-----|
| | | | | | | | 1 | 2 | 3 |
| 1/2" | 2.000 | .625 | 2.625 | .250 | 4.000 | 1.500 | 1 | 1 | 1 |
| 3/4" | 2.500 | .820 | 3.250 | .250 | 4.000 | 1.500 | 1 | 1 | 1 |
| 1" | 2.750 | 1.050 | 3.500 | .250 | 4.000 | 1.500 | 1 | 1 | 1 |
| 1 1/4" | 3.125 | 1.660 | 3.875 | .250 | 4.000 | 1.500 | 1 | 1 | 1 |
| 1 1/2" | 3.625 | 1.900 | 4.500 | .250 | 4.000 | 2.000 | 1 | 1 | 2 |
| 2" | 4.250 | 2.380 | 5.000 | .375 | 4.000 | 2.000 | 2 | 1 | 2 |
| 2 1/2" | 5.000 | 2.880 | 5.875 | .375 | 4.000 | 2.500 | 3 | 2 | 4 |
| 3" | 5.750 | 3.500 | 6.625 | .375 | 4.000 | 2.500 | 3 | 3 | 4 |
| 3 1/2" | 6.375 | 4.000 | 7.250 | .500 | 4.000 | 2.500 | 5 | 4 | 7 |
| 4" | 7.000 | 4.500 | 7.875 | .500 | 4.000 | 3.000 | 7 | 5 | 10 |
| 5" | 8.375 | 5.562 | 9.250 | .625 | 4.000 | 3.000 | 9 | 7 | 14 |
| 6" | 9.750 | 6.625 | 10.625 | .625 | 4.000 | 3.000 | 15 | 10 | 22 |
| 8" | 12.000 | 8.625 | 13.000 | .875 | 4.000 | 3.500 | 26 | 15 | 38 |
| 10" | 14.125 | 10.750 | 15.250 | 1.000 | 4.000 | 4.000 | 47 | 25 | 67 |
| 12" | 16.500 | 12.750 | 17.750 | 1.125 | 5.000 | 4.000 | 79 | 39 | 113 |
| 14" | 19.000 | 14.000 | 20.250 | 1.250 | 5.000 | 4.750 | 103 | 54 | 150 |
| 16" | 21.125 | 16.000 | 22.500 | 1.500 | 5.000 | 4.875 | 151 | 74 | 218 |
| 18" | 23.375 | 18.000 | 24.750 | 1.625 | 5.000 | 4.500 | 200 | 92 | 285 |
| 20" | 25.625 | 20.000 | 27.000 | 1.750 | 6.000 | 4.750 | 280 | 124 | 390 |
| 24" | 30.375 | 24.000 | 32.000 | 2.000 | 6.000 | 5.500 | 470 | 200 | 650 |

- 1) ALL DIMENSIONS ARE IN INCHES.
- 2) WEIGHTS ARE ESTIMATED FOR STEEL, MULTIPLY X 1.01 FOR STAINLESS STEEL.
- 3) HOLE SIZE (WERE REQUIRED DUE TO BOLT SPACING) SHALL BE THE SAME AS THE FLANGE BOLT HOLE.
- 4) DIMENSIONS PER API 590 FIRST EDITION, 1985.
- 5) HANDLE WIDTH FOR LINE BLIDS: 1/2" THRU 6" - 1.000; 8" THRU 24" - 1.500;

LINE & SPECTACLE BLINDS

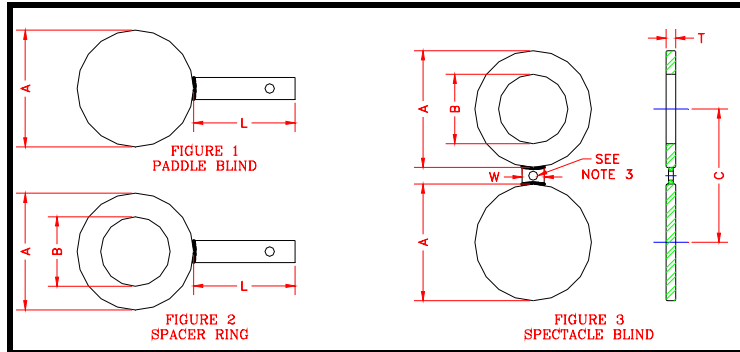
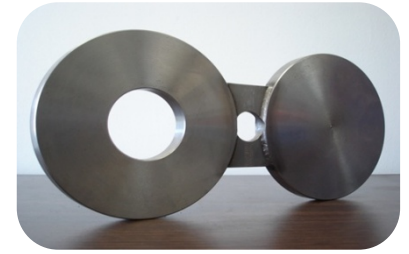

600# ANSI FLANGE RATING

| LINE SIZE | A | B | C | T | L | W | WEIGHT | | |
|-----------|--------|--------|--------|-------|-------|-------|--------|-----|-----|
| | | | | | | | 1 | 2 | 3 |
| 1/2" | 2.000 | .625 | 2.625 | .250 | 4.000 | 1.500 | 1 | 1 | 1 |
| 3/4" | 2.500 | .820 | 3.250 | .250 | 4.000 | 1.500 | 1 | 1 | 1 |
| 1" | 2.750 | 1.050 | 3.500 | .250 | 4.000 | 2.250 | 1 | 1 | 1 |
| 1 1/4" | 3.125 | 1.440 | 3.875 | .375 | 4.000 | 2.250 | 1 | 1 | 1 |
| 1 1/2" | 3.625 | 1.680 | 4.500 | .375 | 4.000 | 2.625 | 1 | 1 | 2 |
| 2" | 4.250 | 2.160 | 5.000 | .375 | 4.000 | 2.250 | 2 | 2 | 3 |
| 2 1/2" | 5.000 | 2.640 | 5.875 | .500 | 4.000 | 2.625 | 3 | 2 | 4 |
| 3" | 5.750 | 3.260 | 6.625 | .500 | 4.000 | 2.625 | 5 | 4 | 7 |
| 3 1/2" | 6.250 | 3.760 | 7.250 | .625 | 4.000 | 3.000 | 6 | 5 | 9 |
| 4" | 7.500 | 4.260 | 8.500 | .750 | 4.000 | 3.000 | 9 | 7 | 14 |
| 5" | 9.375 | 5.300 | 10.500 | .875 | 4.000 | 3.375 | 15 | 13 | 25 |
| 6" | 10.375 | 6.360 | 11.500 | 1.125 | 4.000 | 3.375 | 23 | 17 | 36 |
| 8" | 12.500 | 8.330 | 13.750 | 1.375 | 5.000 | 3.750 | 42 | 27 | 65 |
| 10" | 15.625 | 10.420 | 17.000 | 1.375 | 5.000 | 4.125 | 85 | 53 | 132 |
| 12" | 17.875 | 12.390 | 19.250 | 1.625 | 5.000 | 4.125 | 127 | 73 | 193 |
| 14" | 19.250 | 13.620 | 20.750 | 1.750 | 5.000 | 4.500 | 147 | 79 | 218 |
| 16" | 22.125 | 15.620 | 23.750 | 2.000 | 6.000 | 4.875 | 237 | 140 | 365 |
| 18" | 24.000 | 17.620 | 25.750 | 2.125 | 6.000 | 5.250 | 310 | 153 | 450 |
| 20" | 26.750 | 19.562 | 28.500 | 2.500 | 6.000 | 5.250 | 405 | 235 | 625 |
| 24" | 31.000 | 23.500 | 33.000 | 2.875 | 6.000 | 6.000 | 645 | 335 | 970 |

900# ANSI FLANGE RATING

| LINE SIZE | A | B | C | T | L | W | WEIGHT | | |
|-----------|--------|--------|--------|-------|-------|-------|--------|-----|------|
| | | | | | | | 1 | 2 | 3 |
| 1/2" | 2.375 | .625 | 3.250 | .250 | 5.000 | 1.500 | 1 | 1 | 1 |
| 3/4" | 2.625 | .820 | 3.500 | .250 | 5.000 | 1.625 | 1 | 1 | 1 |
| 1" | 3.000 | 1.050 | 4.000 | .250 | 5.000 | 2.250 | 1 | 1 | 1 |
| 1 1/4" | 3.375 | 1.440 | 4.375 | .375 | 5.000 | 2.250 | 1 | 1 | 1 |
| 1 1/2" | 3.750 | 1.680 | 4.875 | .375 | 5.000 | 2.625 | 2 | 2 | 2 |
| 2" | 5.500 | 2.160 | 6.500 | .500 | 5.000 | 2.250 | 3 | 3 | 5 |
| 2 1/2" | 6.375 | 2.640 | 7.500 | .500 | 5.000 | 2.625 | 6 | 5 | 9 |
| 3" | 6.500 | 3.260 | 7.500 | .625 | 5.000 | 2.625 | 8 | 7 | 11 |
| 4" | 8.000 | 4.260 | 9.250 | .750 | 5.000 | 3.000 | 13 | 11 | 20 |
| 5" | 9.625 | 5.300 | 11.000 | .875 | 5.000 | 3.375 | 20 | 17 | 35 |
| 6" | 11.250 | 6.360 | 12.500 | 1.000 | 5.000 | 3.375 | 35 | 28 | 58 |
| 8" | 14.000 | 8.330 | 15.500 | 1.375 | 5.000 | 3.750 | 63 | 49 | 107 |
| 10" | 17.000 | 10.420 | 18.500 | 1.625 | 5.000 | 4.125 | 117 | 89 | 200 |
| 12" | 19.500 | 13.390 | 21.000 | 1.875 | 5.000 | 4.125 | 172 | 127 | 290 |
| 14" | 20.375 | 13.625 | 22.000 | 2.125 | 6.000 | 4.500 | 212 | 150 | 350 |
| 16" | 22.500 | 15.625 | 24.250 | 2.375 | 6.000 | 4.875 | 286 | 196 | 468 |
| 18" | 25.000 | 17.625 | 27.000 | 2.625 | 6.000 | 5.250 | 407 | 275 | 665 |
| 20" | 27.375 | 19.562 | 29.500 | 2.875 | 6.000 | 5.250 | 510 | 380 | 850 |
| 24" | 32.875 | 23.500 | 35.500 | 3.500 | 6.000 | 6.000 | 645 | 505 | 1120 |

- 1) ALL DIMENSIONS ARE IN INCHES.
- 2) WEIGHTS ARE ESTIMATED FOR STEEL, MULTIPLY X 1.01 FOR STAINLESS STEEL.
- 3) HOLE SIZE (WERE REQUIRED DUE TO BOLT SPACING) SHALL BE THE SAME AS THE FLANGE BOLT HOLE.
- 4) DIMENSIONS PER API 590 FIRST EDITION, 1985.
- 5) HANDLE WIDTH FOR LINE BLIDS: 1/2" THRU 6" - 1.000; 8" THRU 24" - 1.500;